



GLO-1060

(WHEEL BALANCER)

OPERATION MANUAL

DATE INSTALLED: _____

SERIAL # _____

MANUFACTURING DATE: _____

(EAGLE - GLOBAL : UNITE)



GLO-1060

WHEEL BALANCER

INDEX

1- Introduction	Page 4
Overview.....	Page 4
Technical data.....	Page 4
General safety rules.....	Page 4
Safety features.....	Page 4
2- Installation.....	Page 5
3- Operation	Page 6
Control panel.....	Page 6
Display	Page 6
Keys description	Page 6
4- Mounting the tire	Page 7
5- Data input (Auto).....	Page 8
6- Data input (Manual).....	Page 9
7- Aluminum rims	Page 10
8- Balancing a tire	Page 11
9- Calibration routine.....	Page 12
10- Warranty	Page 13

INTRODUCTION

Overview:

When tires are out of balance, it will cause vibration and reduce traction. Tires may wobble; bearings and other rotating parts can be damaged. Balancing tires can eliminate or lesson such problems. This wheel balancer offers digital data display; with a maximum capacity of 60kg; a self-calibration program, and auto-inputs for distance and rim diameter values. The computer can do multiple calculations (for aluminum alloy wheels with internal weight placement), allowing for greater accuracy and adjustment.

TECHNICAL DATA

Max wheel weight:	65KG/143lbs
Motor power:	180-250w
Power supply:	110v/60Hz/1PH
Rim diameter:	(10"-24") 265-615mm
Rim width:	(1.5"-20") 40-510mm
Balancing speed:	200 rpm
Balancing precision:	±1g
Noise:	<70dB(A)

(Please check the motor plate of your machine before use)

GENERAL SAFETY RULES For Operation

- Carefully read the operation manual before using the machine.
- Keep this manual readily available for further reference.
- Write the serial number (located on back of machine) on the cover of this manual. This is necessary information for any future issues.
- Avoid disassembling or substituting accessories, as this can affect operation. If repairs are required, please contact your supplier's Service Department.
- Do not use compressed air at high pressure when cleaning equipment.
- Keep the display and keyboard clean. Do not use corrosive cleaners.
- Always make sure the tire is secured on the shaft. (Do not use a hammer, or otherwise over tighten the speed nut.)
- Wear appropriate clothing. Only authorized personnel should be allowed to operate the machinery.
- Keep machine free of unnecessary clutter.
- Do not use the wheel balancer beyond the specified parameters as stated in this manual.

Safety features

- Stop button: This button is only to be used in an emergency.
- Hood: To protect against debris or incorrectly attached wheel weights which might be flung from a spinning tire.
- Safety switch: To prevent operation without lowering the hood.

INSTALLATION

Assembly & Set-Up

- Inspect unit for any possible shipping damage; and take an inventory of the contents. Verify nothing is damaged or missing. If there are any questions about operating the machine, please contact your supplier.

Standard accessories:

Wheel-weight pliers	1pc
Caliper	1pc
Cones	4pcs
Quick nut	1pc
Plastic Cup	1 pc
Hood	1 pc

Optional accessories as below:

Light Passenger Truck Cone Set	1set
--------------------------------	------

- This wheel balancer should be installed on a firm, level concrete floor or similar surface. Failure to do so can cause measurement errors.
- There should be 500mm (1.5') clear space around the wheel balancer.
- Secure to the floor via the hole in the unit's base (optional).

Electrical Connection

- Be sure of appropriate electrical connection. Unit should be plugged directly into the wall.
- The plug must have ground protection.

OPERATION

CONTROL PANEL

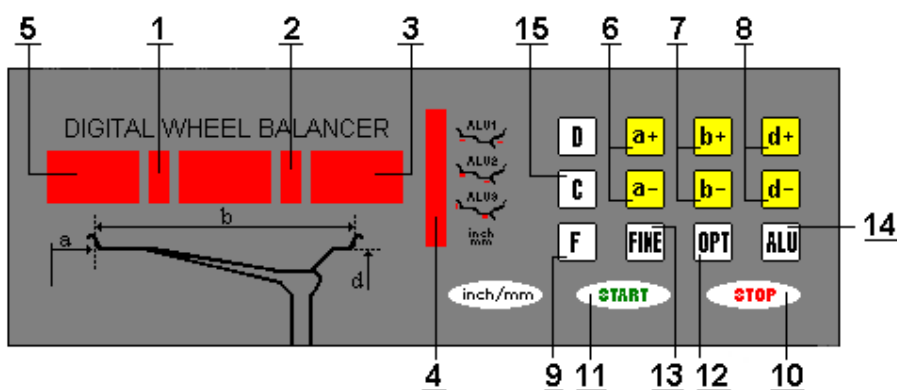

- | | |
|---|--|
| 1. Display: Inner side UNBALANCE POSITION | 2. Display: Outer side UNBALANCE POSITION |
| 3. Display: Outer side UNBALANCE VALUE | 4. Display: Selected type of correction |
| 5. Display: Inner side UNBALANCE VALUE | 6. Distance value input |
| 7. Width value input | 8. Diameter value input |
| 9. "Function" | 10. "Stop" (in case of emergency only) |
| 11. "Start" (to begin cycle) | 12. "Options" |
| 13. "Fine" (threshold key) | 14. "Aluminum" (correction type selection) |
| 15. "Clear" (special functions) | |

Note: Push the keys only with your fingers; do never use pliers or on other pointed object.

KEY FUNCTIONS

Entering the "A" parameter	↑ (or) ↓
Entering the "B" parameter	↑ (or) ↓
Entering the "D" parameter	↑ (or) ↓
Function key	F
Displaying the values below threshold	FINE
Aluminum Selection	ALU
Calibration Routine	D (+) C
Conversion: "grams" to "ounces"	STOP (+) a ↑ (+) a ↓
Conversion: "mm" to "inches" (width)	F (+) b ↑ (or) F (+) b ↑
Conversion: "mm" to "inches" (diameter)	F (+) d ↑ (or) F (+) d ↑
To "Start" balance	START
Emergency "Stop"	STOP
Enable "Start" by closing hood	F (+) STOP

MOUNTING THE TIRE

- Install the main shaft.

Before installing the main shaft, clean with alcohol or gasoline to remove any grease.

Using the Allen-head bolt included with the machine, secure the threaded shaft. Use the hexagonal Allen wrench, also included.

- Mount the Tire.

Several cones of varying sizes are included with the balancer to accommodate different size wheel-rims. Select the appropriate cone, and slide onto the main shaft.

There are two (2) methods for mounting the tire. (See illustrations below.) In the first method, install the cone first, then the tire and then the cup and speed nut assembly. This method is more accurate method, and therefore preferred.

The second method allows an alternative for the occasional situation where the first method may not be applicable. To use this alternative method, the plastic cup must be removed from the speed nut. (See illustration below.)

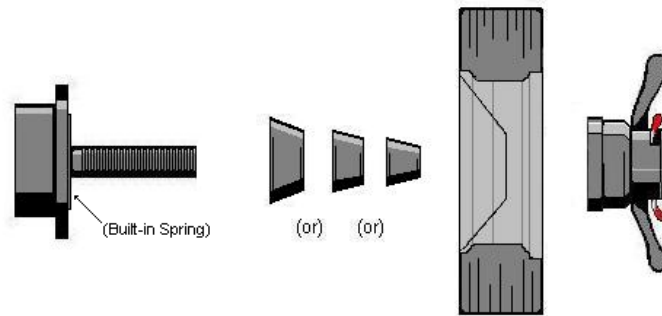

(Preferred Method)

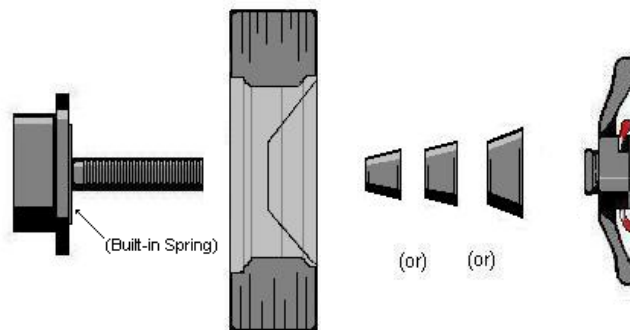
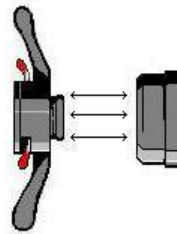

(Alternate Method)

DATA INPUT (Auto)

A. Standard wheel

- Hold the Distance Arm against the rim for approximately two (2) seconds. The Balancer will read and store the value input for the Distance (A) and Diameter (D) of the rim. Return the Distance Arm to rest. Values will be displayed on the Main Board. (See illustration below.)

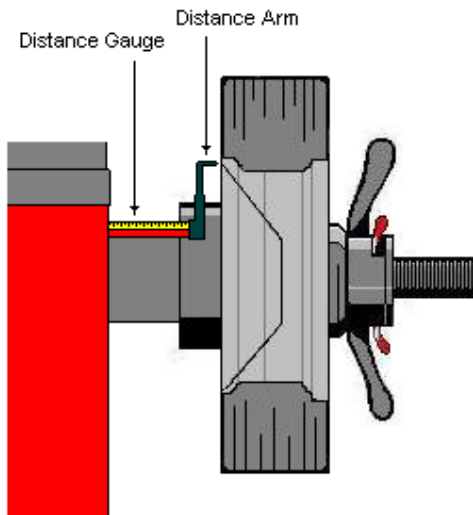

- Input the 'B' parameter (width) value for the wheel. Using the caliper included with the machine, measure the width of the wheel from inside to outside rims. Read the measurement off the caliper, and input the value by depressing the '**B**' "up" and "down" arrow keys until it displays the desired measurement.

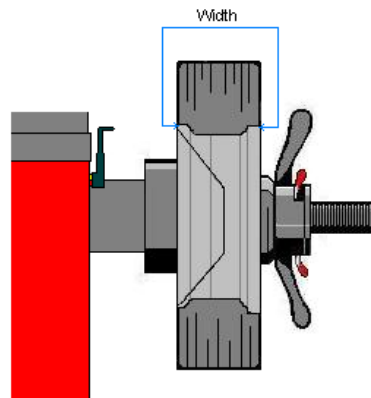

DATA INPUT (Manual)

B. Standard wheel

- Input the 'A' parameter (distance) value for the wheel. Extend and pivot the Distance Gauge Arm to the wheel rim. (See illustration below.) Read the measurement off the gauge, and input the value by depressing the 'A' "up" and "down" arrow keys until it displays the desired measurement. (This function can be used for Normal, ALU1 and ALU2 modes.)

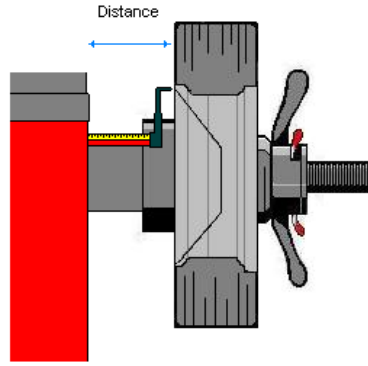

- Input the 'B' parameter (width) value for the wheel. Using the caliper included with the machine, measure the width of the wheel from inside to outside rims. Read the measurement off the caliper, and input the value by depressing the 'B' "up" and "down" arrow keys until it displays the desired measurement.

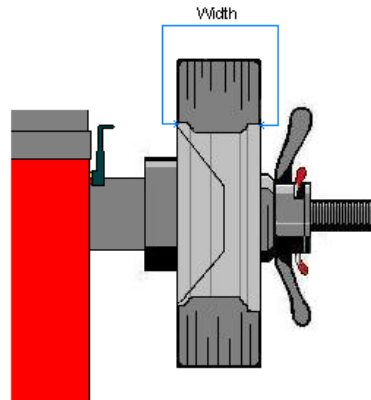

- Input the 'D' parameter (diameter) value for the wheel. Read the diameter off the tire, and input the value by depressing the 'D' "up" and "down" arrow keys until it displays the desired measurement.

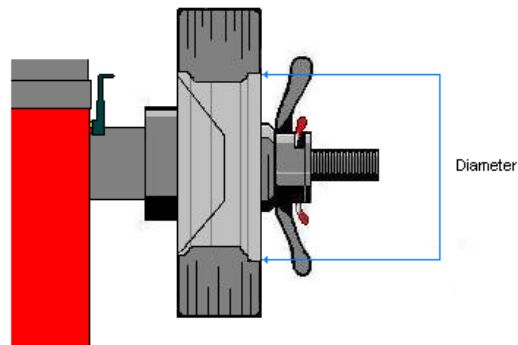

C. Aluminum Rims

Select type of aluminum rim by pressing the ALU key. The indicator will light up displaying your selection.

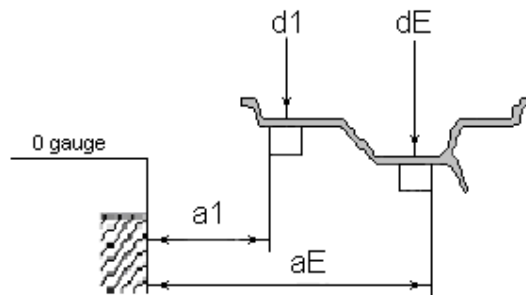

(Fig. 5)

ALU1 : for balancing light alloy wheel rims by applying adhesive weights to the side of the rim.

ALU2 : for balancing alloy rims by applying hidden external adhesive weights.

ALU3 : for combined balancing: clip-on weight on outer edge and adhesive weight on the inner.

Press a \uparrow , a \downarrow button, to modify the distance number(a1)

Press d \uparrow , d \downarrow button, it can modify the diameter number(d1)

Press a \uparrow , a \downarrow button, it can modify the distance number(aE)

Press d \uparrow , d \downarrow button, it can modify the diameter number(dE)

C. Inputting Parameters for static balancing

Press ALU button to choose ALU-S model.

Press a \uparrow , a \downarrow button, to modify the distance value

Press d \uparrow , d \downarrow button, to modify the diameter value

BALANCING THE TIRE

- 1- Remove all wheel-weights from tire.
- 2- Once tire is properly mounted and parameters have been in-put, press START.
(If optional hood is present, lower hood first.)
- 3- Tire will spin (cycle) and then stop.
- 4- Display will show the amount of imbalance.

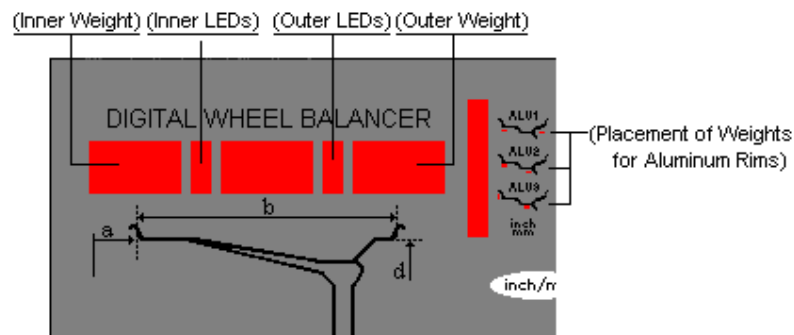

5- The **Outer Weight** display will show the amount of weight to be placed on the **outside** of the rim. Rotate the tire by hand until all four (4) of the Outer LEDs are lit. Place the appropriate weight on the **outside** of the rim at 12:00 (top of wheel rim).

6- The **Inner Weight** display will show the amount of weight to be placed on the **inside** of the rim. Rotate the tire by hand until all four (4) of the Inner LEDs are lit. Place the appropriate weight on the **inside** of the rim at 12:00 (top of wheel rim).

7- Press START again. (If optional hood is present, lower hood first.)

Display should now read "00" and "00" indicating a balanced tire.

Balancing procedure is complete.

WHEEL BALANCER CALIBRATION PROGRAM

Wheel balancer self-calibration program

Note: The wheel balancer comes pre-calibrated from the factory.

You do not need to calibrate the unit before using it.

Only calibrate the balancer if there are problems balancing tires (such as chasing weight, etc.) Be careful to follow each step precisely, correctly and accurately. A balanced tire is preferable, but not necessary; so long as there is no physical damage to the rim.

Do not use a tire with a bent or damaged rim.

Do not attempt to calibrate the balancer with a rim only. You must use a complete tire and rim assembly.

1- Turn the unit on. Mount a medium size (14" - 15") tire on the shaft, and enter the three (3) parameters (Distance, Width and Diameter), as described above.

2- Press F+C button. Display will show [CAL][CAL]. Hold the F and D buttons until the indicators stop blinking, then release the buttons.

3- Lower the hood, and press the START button. The tire will spin. After it stops, the display will read: [Add][100]. Attach a 3.5oz. (100g) weight on the outside of the wheel rim.

4- Lower the hood, and Press the START button, again. The tire will spin a final time. After it stops, the display will read: [End][Cal].

5- The self-calibration is complete. Turn the machine off, then on again to ensure the data is stored properly.

(Self-Calibration values are stored in memory and maintained when the machine is turned off, with storage lasting about 10 years. However Self-Cal may be performed whenever values are in doubt.)



Eagle Global Series Warranty

Eagle Equipment warrants to the original retail purchaser of an Eagle Global Tire Changer or Wheel Balancer that it will replace without charge any part found under normal use, in the United States or Canada, to be defective in materials or workmanship, **for a period of one (1) year from date of purchase**. Warranty covers parts only; purchaser is responsible for any and all labor requirements.

Exclusions

This warranty will not apply to any machine:

1. Which has not been operated or maintained according to specifications
2. Which has been abused, misused, altered or improperly maintained
3. Which has been improperly installed or assembled

Other limitations

This warranty does not cover:

1. Parts needed for normal maintenance
2. Wear parts, which include but are not limited to, speed-nuts, cones, mount heads, and inserts
3. On-site labor

Eagle Equipment reserves the right to make improvements and/or design changes to its equipment without any obligation to previously sold, assembled or fabricated equipment.

There is no other express warranty on the Eagle Global Series equipment and this warranty is exclusive of and in lieu of all other warranties, expressed or implied, including all warranties of merchantability and fitness for a particular purpose.

To the fullest extent allowed by law, Eagle Equipment shall not be liable for loss of use, inconvenience, lost time, commercial loss or other incidental or consequential damages.

Some States do not allow exclusion or limitation of consequential damages or how long an implied warranty lasts, so that the above limitations and exclusions may not apply. This warranty gives you specific legal rights and you may have other rights, which may vary from State to State.