

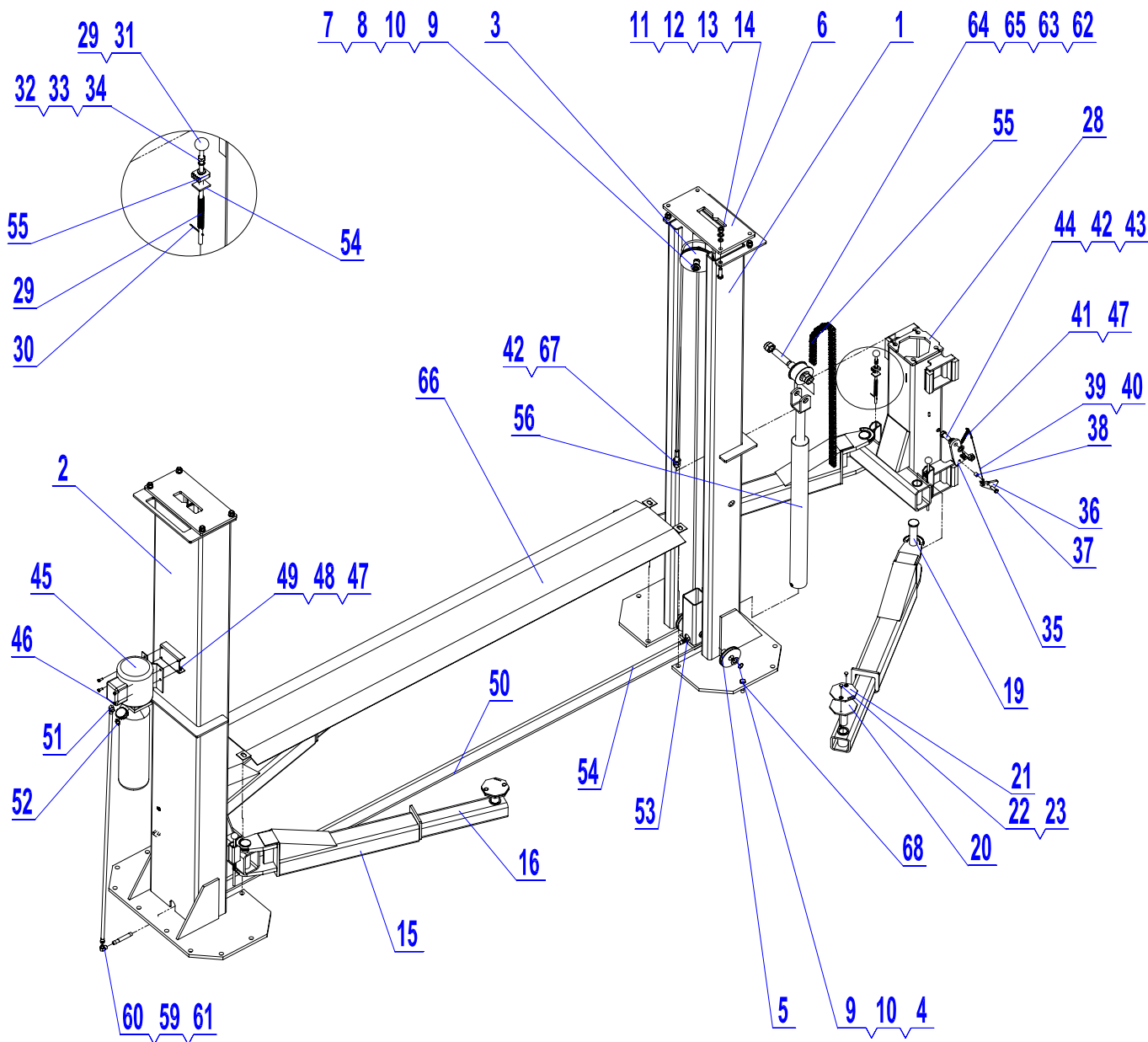

TX TP15KF

KERNEL ITEM NO.165915F<TPO-15B>

Kernel Edition 1.0
Mar.2008





TX TP15KF

Kernel Edition 1.0
Mar.2008

KERNEL ITEM NO.165915F<TPO-15B>

Spare Parts List

ITEM	DESCRIPTION	QTY
1	Assistant stand pole	1
2	Main stand pole	1
3	Sheave shaft	6
4	Sheave	4
5	Oilless bush	4
6	Top cap weldment	2
7	Sheave	2
8	Oilless bush	2
9	Bushing	6
10	Shaft washer	6
11	Bolt	8
12	Flat washer	8
13	Elastic washer	8
14	Nut	8
15	Swing arms	4
16	Moveable arms	4
17	Cover board	4
18	Block	8
19	Pin	4
20	Pad weld	4
21	Rubber washer	4
22	Big head bolt	8
23	Nut	8
24	Notch board	4

ITEM	DESCRIPTION	QTY
25	Board for isolation	8
26	Ring	2
27	Shaft bush	4
28	Carriages weldment	2
29	Pull pin	4
30	Pin	4
31	Plastic ball of handle	4
32	Flat washer	4
33	Spring washer	4
34	Nut	4
35	Detent weldment	2
36	Active board	2
37	Bolt	2
38	Sheath	2
39	Pull rope	2
40	Bushing	4
41	Pullback spring	2
42	Bushing	8
43	Self-lock nut	2
44	Bolt	2
45	Hhydraulic pump	1
46	Bolt	4
47	Bushing	4
48	Elastic washer	4

ITEM	DESCRIPTION	QTY
49	Nut	4
50	Steel wire	2
51	Outside direct fitting	1
52	Hydraulic pump fitting	1
53	Through fitting	2
54	Hose II	1
55	Chain	2
56	Hydraulic cylinder subassembly	2
57	Throttle	2
58	Sping	2
59	Outside through fitting	1
60	Elbow fitting	1
61	Hose II	1
62	Idler wheel	2
63	Oilless bush	2
64	Shaft	2
65	Self-lock nut	4
66	Protective motherboard	1
67	Self-lock nut	8
68	Anchor bolt	16

* Easily Worn Parts